

# Pump AL0918BCD

## Operation And Maintenance Manual

---

**AM** American  
Mfg Company  
*Quality Mud Pumps and Parts*

### Factory/Sales Office

P.O. Box 640  
736 19th Avenue NE  
St. Joseph, Minnesota 56374

**(888) 299-3412** ~ Toll Free  
(320) 363-7273 ~ Phone  
(320) 363-7274 ~ Fax

[info@american-manufacturing.com](mailto:info@american-manufacturing.com)  
[www.american-manufacturing.com](http://www.american-manufacturing.com)



## Operation And Maintenance Manual For AL0918BCD Pump

### Summary:

This is a manual for American Mfg Company AL0918BCD triplex piston pump with ball valves.

### Alternate model versions:

The standard model comes with **left hand** pinion shaft and **square keyway** shaft end.  
Model AL0918BCD-R comes with **right hand** pinion shaft and **square keyway** shaft end.



## AL09 Piston Pump Data

11.6 BHP Continuous Duty (13.8 BHP Intermittent Duty)

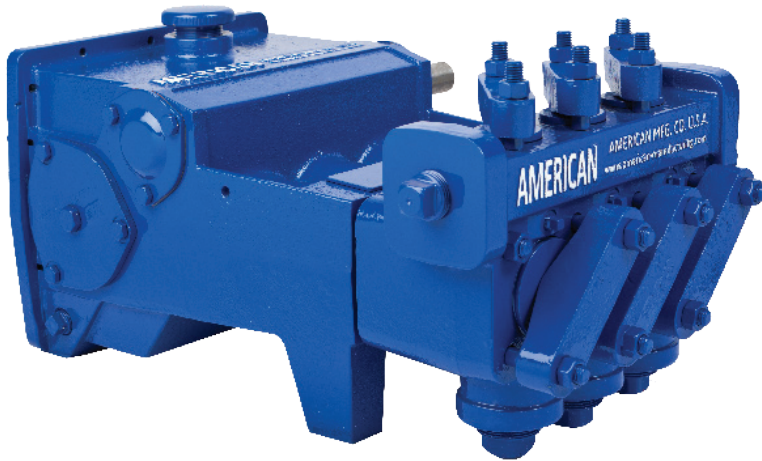

Specifications	
Pump Model	AL0918
Configuration	Horizontal Triplex Piston
Number of Pistons	3
Stroke Length	2.25 Inches (57.2 mm)
Frame Load Rating	2800 lbs. (1,270 kg)
Pump Weight	200 lbs. (90.7 kg)
Direction of Rotation	Top of Shaft away from head
Internal Gear Rotation	3.6:1
Intermittent Duty Speed Rating	890 RPM (Jackshaft)
Continuous Duty Speed Rating	750 RPM (Jackshaft)
Ball Valve Max Speed Rating	625 RPM
Minimum Speed	360 RPM
Mechanical Efficiency	85%
Lubrication System	Splash, Gravity Return
Lube Oil Capacity	2.25 Quarts
Lube Oil Type	SAE 30
Maximum Fluid Temperature	140 °F (250 °F Capability)
Minimum Fluid Temperature	0 °F (-20 °F Capability)
Standard Suction Size	1.50 Inch NPT (38.1 mm)
Standard Discharge Size	1.00 Inch NPT (25.4 mm)
Fluid End Material	Cast Iron
Valve Type	Disc Valve / Ball Valve
Hydraulic Motor Mount	SAE C - 4 Bolt with 1.25"-14T

### Performance Rating

Pump Model	Diameter		Displacement/REV		Maximum Pressure		Pump Capacity @ Input Speed (RPM)									
							350 RPM		625 RPM		700 RPM		750 RPM		890 RPM	
							Inch	mm	Gallon	Liter	PSI	kg/cm <sup>2</sup>	gpm	lpm	gpm	lpm
AL0918	2.25	57.2	0.0323	0.122	700	49.2	11.3	43	20.2	76	22.6	86	24.2	92	28.7	109

Specifications subject to change without notice.

Horsepower is based on 85 or 90% efficiency. Actual application horsepower requirements can be calculated using this equation:  $BHP = (GPM * PSI) / (1714 * 0.85 \text{ or } 0.90)$  Pump capacities listed are based on 100% volumetric efficiency.

This document contains American Mfg Company proprietary and confidential information. It is loaned for limited purposes only and remains the property of American Mfg Company. It may not be reproduced in whole or part or disclosed to third parties without the prior written consent of American Mfg Company. The document is to be returned to American Mfg Company upon request and in all events upon completion of the use for which it was used.



## Table Of Contents

1.0	Important Safety Instructions.....	6
2.0	AL0918BCD Pump Features.....	7
3.0	Storage Instructions.....	8
3.1	Short Term Storage.....	8
3.2	Short Term Storage for Severe Environments.....	8
3.3	Long Term Storage.....	8
3.4	Returning a Stored Pump to Operation.....	9
3.5	Precautions during Freezing Weather.....	9
4.0	Installation Guidelines.....	10
4.1	General Location.....	10
4.2	Mounting Pump to Foundation and Power Source.....	10
4.3	Suction Piping Recommendations.....	10
4.4	Discharge Piping Recommendations.....	11
5.0	How to Start a Pump.....	13
6.0	Lubrication of Power End.....	14
6.1	Recommended Lubricants.....	14
6.2	Oil Changes.....	14
7.0	Inspection and Preventative Maintenance Chart.....	16
8.0	Component Parts List.....	17
9.0	Service Procedures.....	21
9.1	Removing the Fluid Cylinder.....	24
9.2	Replacing Valves.....	26
10.0	Servicing the Power End.....	29
10.1	Replacing Piston Rod Oil Seals.....	29
10.2	Replacing Power End Bearings & Crankshaft.....	30
11.0	Fastener Torque Requirements.....	35
12.0	Critical Clearances.....	36
13.0	Trouble-Shooting Pumps.....	37
14.0	Ordering Parts.....	41
15.0	Additional Pump Assembly Products.....	42
16.0	Glossary of Commonly Used Terms.....	44
17.0	Reference Information.....	46
18.0	Maintenance Log.....	47

## List of Figures and Charts

Table 1	Pipe Pressure Chart.....	11
Table 2	Lubricant Recommendations.....	15
Table 3	Maintenance Chart.....	16
Table 4	Component Item Numbers.....	20
Table 5	Service Tool Item Numbers.....	21
Table 6	Torque Values for Critical Pump Fasteners.....	35
Table 7	Clearance Chart.....	36
Table 8	Replacement Rubber Item Numbers.....	42
Figure 1	AL0918BCD Pump Assembly with Pinion Shaft.....	7
Figure 2A	Power End Components.....	17
Figure 2B	Power End Components.....	18
Figure 3	Fluid End Components.....	19
Figure 4	Using the Knock Out Tool.....	27
Figure 5	Additional Pump Assembly Products.....	42
Figure 6	Pump Mount Bolt Pattern.....	43

## 1.0 Important Safety Instructions

**WARNING:** Many accidents occur every year through careless use of mechanical equipment. You can avoid hazards associated with high pressure equipment by always following the safety precautions listed below.

- AM SHUT DOWN OR DISENGAGE** the pump and all accessory equipment before attempting any type of service. Failure to do this could cause electrical shock or injury from moving pump parts or components under high pressure. Always adhere to "Lock Out" and "Tag Out" procedures. For mobile equipment, be sure engines and hydraulics cannot be accidentally started.
- AM BLEED OFF ALL PRESSURE** to the pump and piping before performing any maintenance on the pump. Failure to do so may spray water or chemicals at high pressure or high temperature onto service personnel.
- AM NEVER OPERATE THE PUMP WITHOUT A PRESSURE RELIEF VALVE**, rupture disc, or other type of properly sized over pressure safety device installed.
- AM ALWAYS USE A PRESSURE GAUGE** when operating the pump. The pressure must never exceed the maximum pressure rating of the pump or damage may occur. This damage can cause leakage or structural damage resulting in injury to personnel.
- AM ENSURE THAT NO VALVES ARE PLACED BETWEEN THE PUMP AND PRESSURE RELIEF VALVE.** If the pump is started with a closed or restricted valve in line before the pressure relief valve, the pump may exceed the rated or designed pressure limits and rupture causing injury to personnel.
- AM USE SHIELDS OR COVERS AROUND PUMPS** when pumping hot water, chemicals, or other hazardous liquids. This precaution can prevent the exposure of service personnel to these fluids should leakage occur.
- AM ALWAYS USE GUARDS** on all belt drives, couplings, and shafts. Guards can prevent personnel from becoming entangled and injured by rotating and reciprocating parts.
- AM USE EXTREME CAUTION WITH SOLVENTS** used to clean or degrease equipment. Most solvents are highly flammable and toxic. Observe all safety instructions on packaging.
- AM FOLLOW NORMAL ENVIRONMENTAL GUIDELINES WHEN** fluids, lubricants, or solvents are disposed of or spilled.
- AM NEVER MODIFY THE PUMP** to perform beyond its rated specifications without proper authorization in writing from **AMERICAN MFG COMPANY**.

## 2.0 AL0918BCD Pump Features

The AL0918BCD pump includes the integral gear reduction pinion shaft and ball valves. Drive shaft standard end comes with 1-1/8" diameter shaft and 1/4" square keyway.

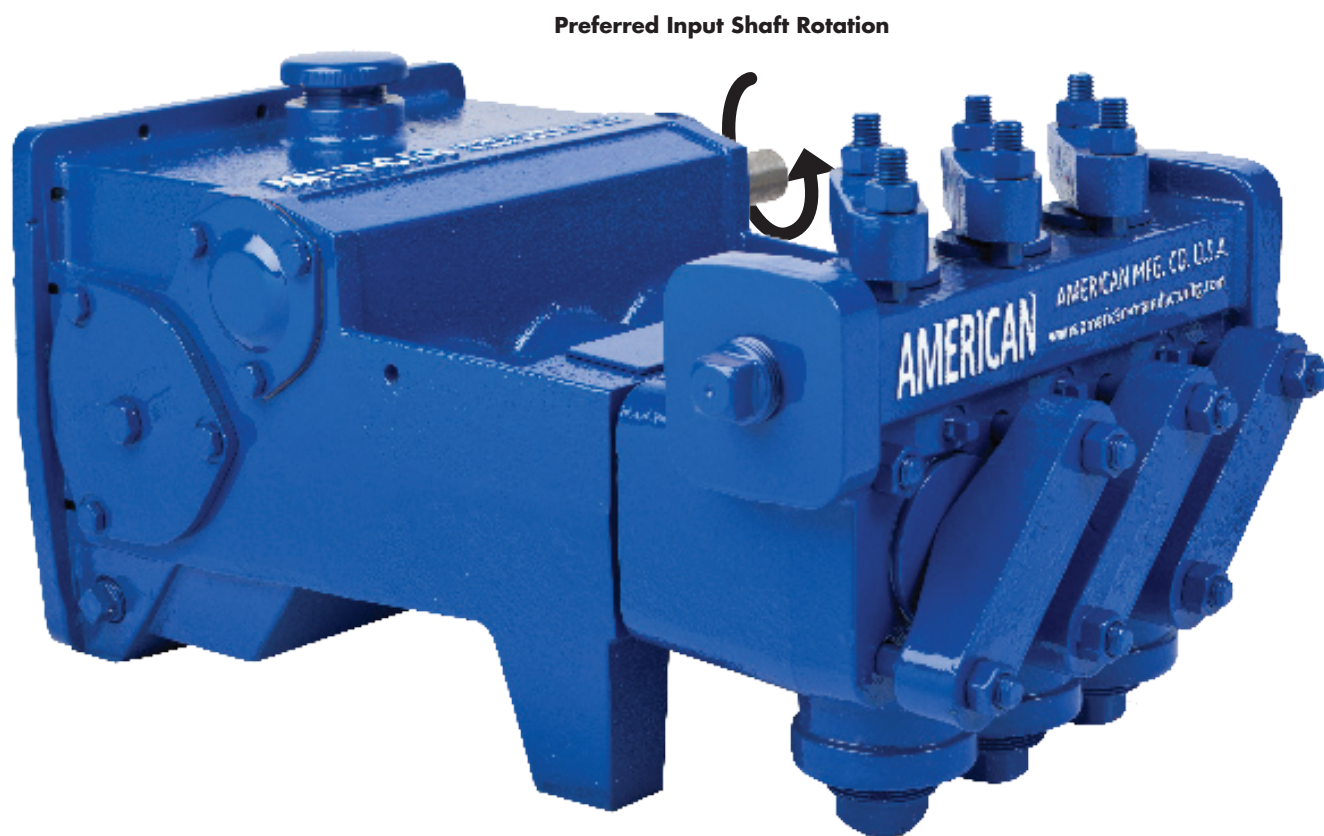

Figure 1: AL0918BCD Pump Assembly with Pinion Shaft



## 3.0 Storage Instructions

Proper storage of your American Mfg Company pump will ensure that it is ready for service when needed. Follow the guidelines below that fit the requirements of your application.

American Mfg Company pumps come from the factory **without crankcase oil** and are prepared for storage periods of up to six (6) months in proper environmental conditions. Indoor storage in a dry, temperature-controlled location is always recommended. If pumps are to be stored short term (less than six (6) months) in a severe environment, they should be prepared using the procedures outlined in the "Short Term Storage for Severe Environments" section 3.2 below. If the pump is to be stored, or is inactive, for periods in excess of six (6) months, it is necessary to prepare the pump as outlined in the "Long Term Storage" Section 3.3. Remember that any fluid that poses an environmental hazard or is toxic must be handled and disposed of properly.

### 3.1 Short Term Storage

If the pump is stored in an indoor, temperature controlled environment for less than six (6) months, no special steps are required to prepare it for storage. As a general rule for pumps in corrosive fluid applications, the fluid end should be drained, flushed with water or other non-corrosive cleanser and compressed air used to blow dry whenever idle.

### 3.2 Short Term Storage for Severe Environments

If the pump has been in service, drain any fluid from pump fluid end, flush the fluid end with water to clean out any of the remaining pumpage and blow dry with compressed air. Pour 1/4 to 1/2 cup of internal rust inhibitor oil described in Table 2 (see Recommended Lubricant Chart, Section 6.0 ), into the suction and discharge ports of fluid end, and then install pipe plugs in openings. Drain the power end (crankcase) oil and remove the oil fill cap (or plug). Pour 1/2 to 1 cup of internal rust inhibitor oil described in Table 2, into the oil fill hole and then install the filler cap. Coat all exposed, unpainted metal surfaces (for example, Driveshaft) with preservative oil. Replace the oil fill cap, and then cover the entire pump with a weather resistant covering such as a canvas or plastic tarp.

### 3.3 Long Term Storage

Long-term storage is defined as any period when the pump is in storage or idle in excess of six (6) months. If the pump has been in service, drain any fluid from the pump fluid end, flush the fluid end with water to clean out any of the remaining pumpage, and blow dry using compressed air. Pour 1/4 to 1/2 cup of internal rust inhibitor oil described in Table 2, into the suction and discharge ports of fluid end, and then install pipe plugs in openings. Remove the piston cup seals as described in Section 9.0 Service Procedures "Replacing Cup Type Pistons" of this manual, seal them in a bag to protect against ozone, and store them in a separate location with a controlled environment where they are protected from UV exposure. Drain the oil from the pump power end. Remove the rear



cover to expose the drive components. Spray all internal parts with a rust preservative that is soluble in lubricating oil while rotating the driveshaft several turns by hand to ensure complete coverage. Replace the rear cover and add ½ to 1 cup of internal rust inhibitor described in Table 2. Spray a rust preventative onto all exterior machined surfaces paying attention to any unpainted areas like the crankshaft extension. Remove the oil fill cap and store with the piston cup seals. Cap the breather opening with a plug or other suitable means in order to keep the preservative atmosphere sealed inside the power end. Never store the pump on the floor or ground. Always place it on a shelf or pallet that is several inches above ground level. Cover the entire pump with a canvas or plastic tarp. Every two months inspect the unit. Rotate the crankshaft by hand at least 4 turns during each inspection. Drain and replace the rust inhibitor after every six (6) months of storage.

## 3.4 Returning a Stored Pump to Operation

Before operating a pump that has been prepared for storage, drain the preservative and lubricating oil mixture from the power end (crankcase). If the pump has a pinion bearing, remove the rear cover and apply recommended crankcase lubricant (Refer to Table 2 in Section 6.0) to the pinion bearings. Reinstall the rear cover, drain plug, breather/filler cap, piston cup seals, and any other components that were removed for storage. Once these steps have been completed, follow the normal pump start up procedures outlined in this manual.

**NOTE:** American Mfg Company can factory prepare units for long term storage for a nominal fee if specified at the time of order.

## 3.5 Precautions during Freezing Weather

Freezing weather can cause problems for equipment when pumping water-based fluids that expand in volume when changing from a liquid to a frozen solid state. When water is left in a pump fluid end and exposed to freezing temperatures, the expansion of the water as it freezes can rupture the fluid cylinder of the pump and cause equipment damage. Injury may result when starting equipment that has been damaged. Whenever the pump is stored or idle in conditions that are near or below freezing, any water based fluids should be removed from the pump. The best way to do this is to run the pump for a few seconds with the suction and discharge lines disconnected or open to atmosphere. This will clear the majority of the fluid from the pumping chamber as well as the suction and discharge manifolds. After the run, blow compressed air through the fluid end to remove all traces of fluid. Remove the bottom plugs and cylinder covers from the fluid cylinder. Drain the liquid from the discharge valves first and then the suction valves by lifting the valves. This ensures all fluid to be drained from the pumping chamber between the suction and discharge valves. As an alternative to the previous procedure, a compatible antifreeze solution can be circulated through the fluid end. RV antifreeze, propylene glycol, is recommended for this purpose. Remember that any fluid that poses an environmental hazard or is toxic must be handled and disposed of properly.

## 4.0 Installation Guidelines

A proper installation is essential to optimal performance, long service life, and reduced maintenance requirements. Take time to thoroughly plan all aspects of your installation.

### 4.1 General Location

It is important to position the pump on as flat and level a surface as possible to assist the splash oil lubrication system. Park mobile equipment, such as sewer cleaner trucks or drilling machines, on as level a surface as possible. Whenever possible the pump should be mounted in a clean, dry location with sufficient lighting and adequate space for easy inspection and maintenance. Locate the pump as close to the suction source as possible to allow for the shortest and most direct routing of the inlet piping.

### 4.2 Mounting Pump to Foundation and Power Source

The AL0918 pump described in this document must be mounted in a horizontal position only. Secure the pump to the mounting surface using the four (4) holes provided in the pump base. Check motor or engine rotation direction to ensure that the top of the pump pinion shaft rotates away from the pump fluid end when in operation. For units that are V-belt driven, check the alignment of the sheaves after the unit is installed on its permanent mounting. Tighten belts to the proper tension as recommended by the belt manufacturer. Verify that the sheaves are in line and parallel to each other with a straight edge.

**CAUTION:** Never operate the pump without the belt guard securely installed. For direct-coupled units, ensure that the shafts are centered and parallel when the driver is mounted to the pump. Follow the coupling manufacturer instructions for installation procedures and tolerances.

**CAUTION:** Never operate the pump without a shaft guard securely installed.

### 4.3 Suction Piping Recommendations

Poor suction piping practices are a very common source of pump problems. To ensure proper operation it is very important to follow good design practice in the installation of the suction system before the pump is operated. A small amount of additional planning and investment in the piping system usually provides for better pump performance and longer periods between service requirements. It is difficult to diagnose many pump problems without the aid of a suction pressure gauge. For this reason, American Mfg Company recommends that a gauge always be installed in the suction line directly before it enters the pump.

The suction line from the fluid source to the pump should be as short and direct as possible. Use rigid piping, non-collapsible hose or a combination of both as circumstances require in your installation. The suction pipe size

should be at least equal to or one size larger than the pump inlet. Long piping runs, low suction heads, or indirect pipe routing may require even greater over sizing of the suction line for proper operation of the pump. A suction and discharge pulsation dampener is recommended to reduce the effects of acceleration head to help when suction conditions are not optimal. In some cases it may be necessary to install a booster pump in the suction line of the pump to obtain sufficient pressure for the pump to operate successfully.

The suction line must be configured so there are no high spots in the line where air pockets can collect. These pockets may make the pump difficult to prime and cause rough, erratic operation. A drain valve or plug should be installed at the low point of the suction line to allow for draining before freezing conditions or for maintenance.

American Mfg Company recommends that all piping be supported independently of the pump. By supporting the piping this way, vibrations are reduced and stress on the pump is kept to a minimum. The use of elbows, nipples, unions, or other fittings should be minimized. Make sure that all joints and connections are airtight. Air leaks reduce the capacity of the pump and can result in cavitation, rough operation, and/or loss of prime. To help isolate mechanical and hydraulic vibrations, American Mfg Company recommends the use of flexible pipe couplings or hose connections between the pump and any rigid piping.

Always ensure that calculated system Net Positive Suction Head available, NPSHa, exceeds pump Net Positive Suction Head Required, NPSHr, by at least 5 feet (1.5 meters) of water for proper operation of the pump. NPSH requirements for each pump model are provided on the product data sheets available through American Mfg Company or your authorized American Mfg Company reseller. American Mfg Company does not recommend using the pump in static lift conditions without prior factory approval.

## 4.4 Discharge Piping Recommendations

1. Route the discharge piping in as short and direct a route as possible. Use the same pipe size as the outlet of the pump. In installations where the discharge piping is in excess of 50 feet (15 meters) it is suggested to use the next larger size pipe to minimize friction losses downstream of the pump.

**CAUTION:** Always use pipe or hose that is designed for your particular pressure requirements. Inadequate pressure ratings can allow hose or pipe to fail, resulting in equipment damage and possibly personal injury. Normal hose pressure ratings are clearly marked on the outer surface of the hose. Working pressure ratings for steel pipe can be obtained from the manufacturer or from the chart shown in Table 1.

Allowable Working Pressure For Steel Pipe (PSI @ 100F)					
Pipe Size (inches)	Pipe Schedule Number				
	40	80	120	160	XX
1/2	2,300	4,100		7,300	12,300
3/4	2,000	3,500		8,500	10,000
1	2,100	3,500		5,700	9,500
1 1/4	1,800	3,000		4,400	7,900
1 1/2	1,700	2,800		4,500	7,200
2	1,500	2,500		4,600	6,300
2 1/2	1,900	2,800		4,200	6,900
3	1,600	2,600		4,100	6,100
4	1,400	2,300	3,350	4,000	5,300
5	1,300	2,090	2,950	3,850	4,780
6	1,210	2,070	2,850	3,760	4,660
8	1,100	1,870	2,840	3,700	3,560

14.5PSI = 1 BAR

Table 1: Pipe Pressure Chart

2. **Always use a pressure gauge in the pump discharge line.** A properly functioning gauge mounted at the pump (and before any valves) is required to accurately determine the operating pressure of a pump and to conduct troubleshooting.
3. Ensure that all piping is supported independently of the pump to reduce vibrations and strain on the pump. Pulsation dampeners on the discharge are recommended to reduce pressure pulsation and resulting vibration. The use of elbows, nipples, unions, or other fittings should be kept to an absolute minimum. Avoid short radius 90° elbows; use two long radius 45° elbows instead. To help isolate mechanical and hydraulic vibrations, American Mfg Company recommends the use of flexible pipe couplings or hose connections between the pump and any rigid piping or the use of pulsation dampeners.
4. A properly adjusted pressure relief valve or rupture disc must be installed directly downstream of the pump to prevent damage or injuries resulting from over pressure or deadhead conditions. The relief valve discharge line must be as large as the pipe outlet of the relief valve. Never install valves in the relief valve discharge line or between the pump and relief valve. American Mfg Company recommends that the discharge be returned to the tank or drain, not back into the pump suction line.
5. It is recommended that a start-up bypass line and valve be installed to allow flow to bypass the relief valve. This allows the pump to start in an unloaded condition (no discharge pressure).

## 5.0 How to Start a Pump

**CAUTION:** Always take special precautions when starting a pump for the first time or after any extended shutdown. **Never assume that someone else has properly prepared the pump and system for operation.** Always check each component of the system prior to every start-up. The checklist that follows is intended to be a general guide for starting a pump in a typical installation. Every installation is different, and each will have different requirements to ensure safe and successful operation. **It is the responsibility of the operator to determine the correct start-up procedure for each installation.**

1. Ensure that the drain plug(s) on the bottom of the pump crankcase have been installed and are tight. Ensure that the oil level sight glass, if equipped, has been properly installed.
2. Check the oil level to ensure that the pump is properly filled with non-detergent motor oil, gear lube, or a synthetic oil as described in Table 2 and that the oil has not been contaminated with water or other contaminants.

**NOTE:** American Mfg Company pumps are shipped with no oil in the power frame and must be filled to the proper level with the proper grade of oil prior to start-up.

3. If accessible, check the piston rods to ensure that they are free from abrasive particles or debris.
4. Ensure that the pressure relief valve and all accessory equipment have been installed and properly adjusted. Verify that all joints are pressure tight.
5. Open the suction line valve to allow fluid to enter pump. Prime the fluid cylinder if necessary on the initial start up or after the system piping has been drained. The valve covers may have to be cracked open to assist with priming.
6. Check to ensure that power is locked out and tagged out. Turn the pump over by hand if possible to ensure free, unobstructed operation.
7. Apply 10 to 20 drops of glycerin, or mineral oil to the pistons, cylinders and piston rods to lubricate the packing and seals.
8. Make sure that all guards are in place and secure. Verify that all personnel are in safe positions and that system conditions are acceptable for operation.
9. The pump is now ready to start. **NOTICE:** Whenever possible, use a bypass in the discharge line to allow the pump to start in the unloaded condition (no discharge and pressure). Slowly close the bypass line to bring the pump into full load conditions. Shut down immediately if the flow becomes unsteady, pressure fluctuates, or if unusual sounds or vibrations are noted.
10. Take temperature readings of the power end and stuffing boxes. Do not exceed 170°F (77°C) on power end.

## 6.0 Lubrication of Power End

### 6.1 Recommended Lubricants

Few factors can influence the life of a pump more than the power end lubricant (oil). Careful selection of the right type of oil for each particular application will help ensure optimal performance from an American Mfg Company pump.

**NOTE:** Lubricant temperatures should not exceed 170° F (77° C) for continuous duty or 180° F (82° C) for intermittent duty applications. Crankcase temperatures that exceed these limits will cause the lubricant to prematurely “break down”. The result will be poor lubrication and failure of power end components.

### 6.2 Oil Changes

Oil changes must be carried out after first 100 hours of operation, and subsequently after every 4,000 hours or at least every 6 months. These intervals may be modified depending on actual operating conditions. This model pump requires 2-1/4 quarts (2.1 liters) of oil.

**AM** Oil should be changed when hot to prevent build up of sludge deposits.

**AM** It is advisable to check oil level daily. If more than 10% of the total capacity has to be added, check for oil leaks.

**AM** Do not mix oils of different types, even if produced by the same manufacturer.

**AM** Never mix mineral and synthetic oils.

**AM** To avoid the risk of scalding or burns, pay attention to oil and power end temperature during an oil change.

**AM** Follow environmental guidelines when changing and disposing of lubricants.

Recommended Lubricant Chart								
		Oil Lubricant				Synthetic Lubricant*		
Type of Service	Ambient Temperature	SAE Grade	ISO Viscosity (cSt@40 C)	SSU Viscosity	Manufacturer Brand Name	SAE Grade	ISO Viscosity (cSt@40 C)	Manufacturer Brand Name
General Service	0 F to 100 F (-18 C to 38 C)	30	100	550	Texaco® Meropa 100 Shell® Omala 100 Shell® Rotella T SAE 30 Exxon® XD-3 30 wt Mobil® Trans HD-30	10W-30	90.0@40 15.0@100	Shell® Rotella T Synthetic SAE 5W-40
						5W-40	99.1@40 13.9@100	Mobil® SCH 627
						NA		
High Ambient Temperature Service	100 F to 130 F (38C to 54 C)	50	220	1,165	Texaco® Meropa 68 Shell® Omala 220 Shell® Rotella T SAE 50 Exxon® HD-3 50 wt Mobil® Trans HD-50	5W-40	90.0@40 15.0@100	Shell® Rotella T Synthetic SAE 5W-40
						5W-40	217@40 29.9@100	Mobil® SCH 630
						NA		
Cold Ambient Temperature Service	0 F to -30 F (-18 C to -34 C)	20	68	350	Texaco® Meropa 68 Shell® Omala 68 Shell® Rotella T SAE 20 Exxon® HD-3 20 wt Mobil® Trans HD-20	5W-30	90.0@40 15.0@100	Shell® Rotella T Synthetic SAE 5W-40
						5W-40	12.0@100	BP® Vanellus E8 ULTRA 5W-30
						10W-30	69.9@100 10.9@100	Mobil® SCH 626
						NA		
Frequent Start/Stop Operation		40	150	775	Texaco Meropa®150			
Specialty Items								
Internal Rust Inhibitor					Cortec® VCI 329			
External Rust Preventative					Texaco® Metal Protective Oil L			

Table 2: Lubricant Recommendations

\*Synthetic lubricants are suggested for high or low temperature service. Cortec® is a registered trademark of Cortec Corporation, St. Paul, MN.



## 7.0 Inspection and Preventative Maintenance Chart

Routine maintenance is an essential part of any successful pump installation. Properly maintained American Mfg Company pumps are designed to offer years of trouble-free service.

Regular maintenance and inspection will keep your pump operating at peak performance. American Mfg Company pumps have been carefully engineered to minimize maintenance requirements and simplify these tasks when they are required. Regular inspections allow operators to become familiar with normal pump operation so they can recognize the signals of potential problems and schedule maintenance. The maintenance chart in Table 3 shown below should be used as a guideline only. Many applications will require adjustment of the intervals shown in this chart for severe or unusual operating conditions.

Interval	Component	Service	Remarks
Break In Period	Crankcase Oil	Change	Drain and refill with new oil after first 100 hours of operation. Ensure that the magnetic drain plugs are cleaned to remove debris.
	Inlet Strainer	Inspect	Clean if required. The amount of material in the strainer will determine the interval of cleaning.
Daily	Complete Pump	Inspect	General inspection of pump and system to check for proper operation of equipment.
	Piston Cup Sets	Inspect	Check the cylinder liner area of the pump for signs of leakage. Replace piston cups if leakage becomes excessive.
	Pump System	Flush	Required for shutdown when pumping fluids that may harden or corrode the pump if left inside once stopped.
	Crankcase Oil	Inspect	Ensure that the oil is at proper level and has not been contaminated by pumpage or condensation.
6 Months / 4,000 Hours	Crankcase Oil	Change	Drain and refill with new oil. Clean magnetic drain plugs.
	Stuffing Box	Inspect	Check the stuffing box bolts with a torque wrench to ensure they are within specification.
	Connecting Rod Bolts	Inspect	Check the connecting rod bolts with a torque wrench to ensure they are within specification. This should be done in conjunction with oil change.

Table 3: Maintenance Chart

## 8.0 Component Parts List

To order service parts or see exact component configurations for your particular pump, refer to the cross-section parts drawing. Contact your local American Mfg Company pump distributor or American Mfg Company if you do not have this information.

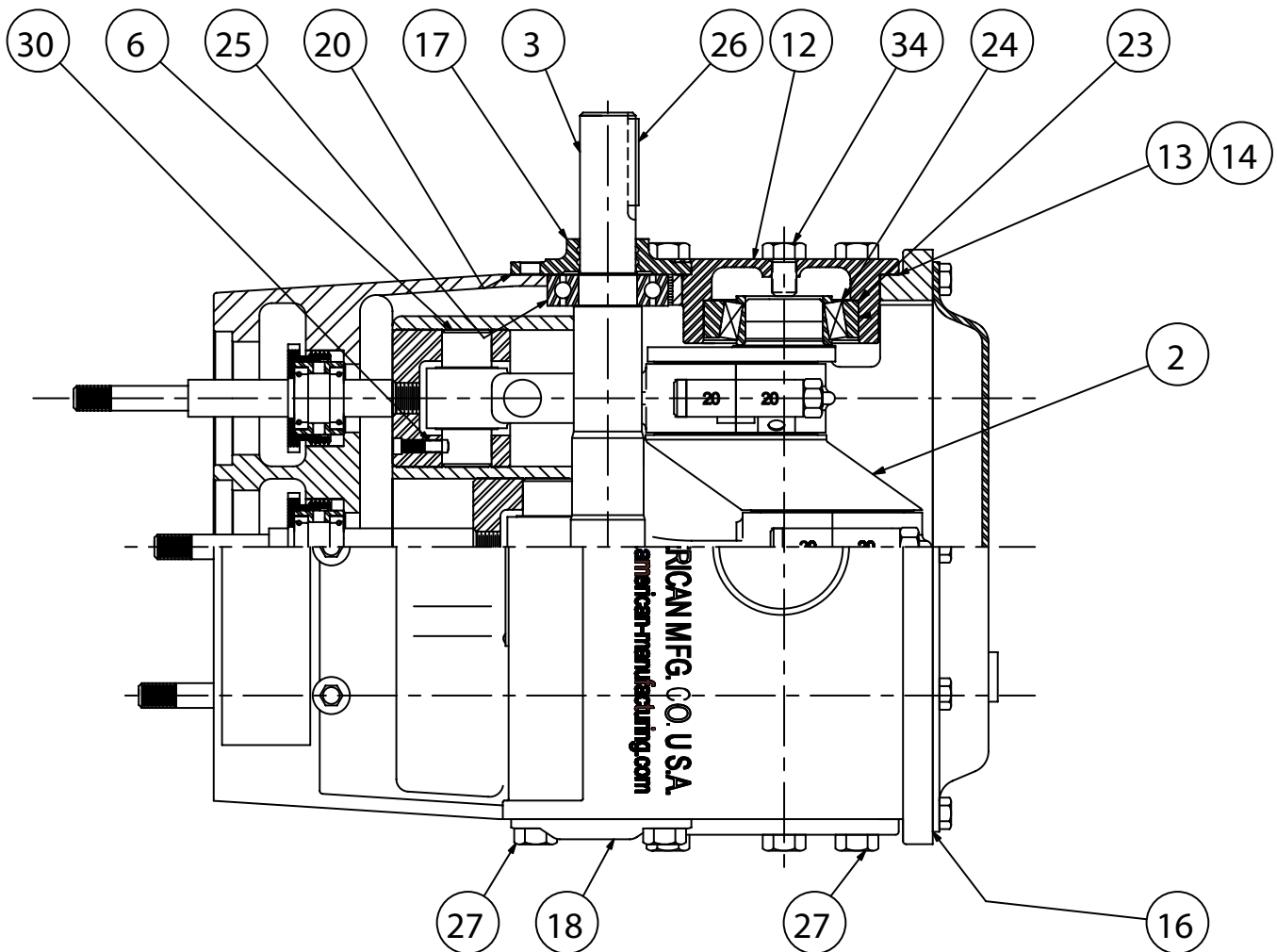

Figure 2A: Power End Components

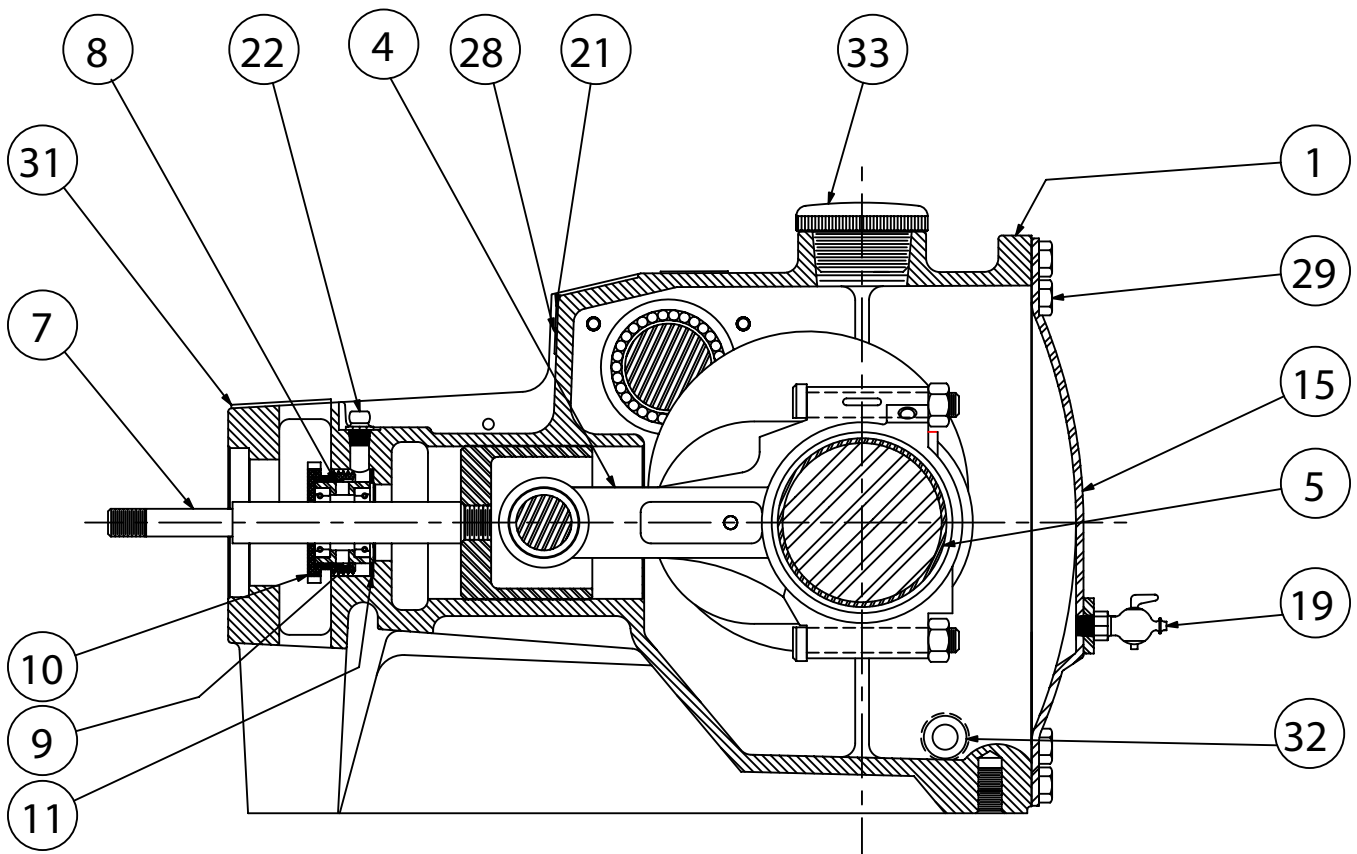

Figure 2B: Power End Components

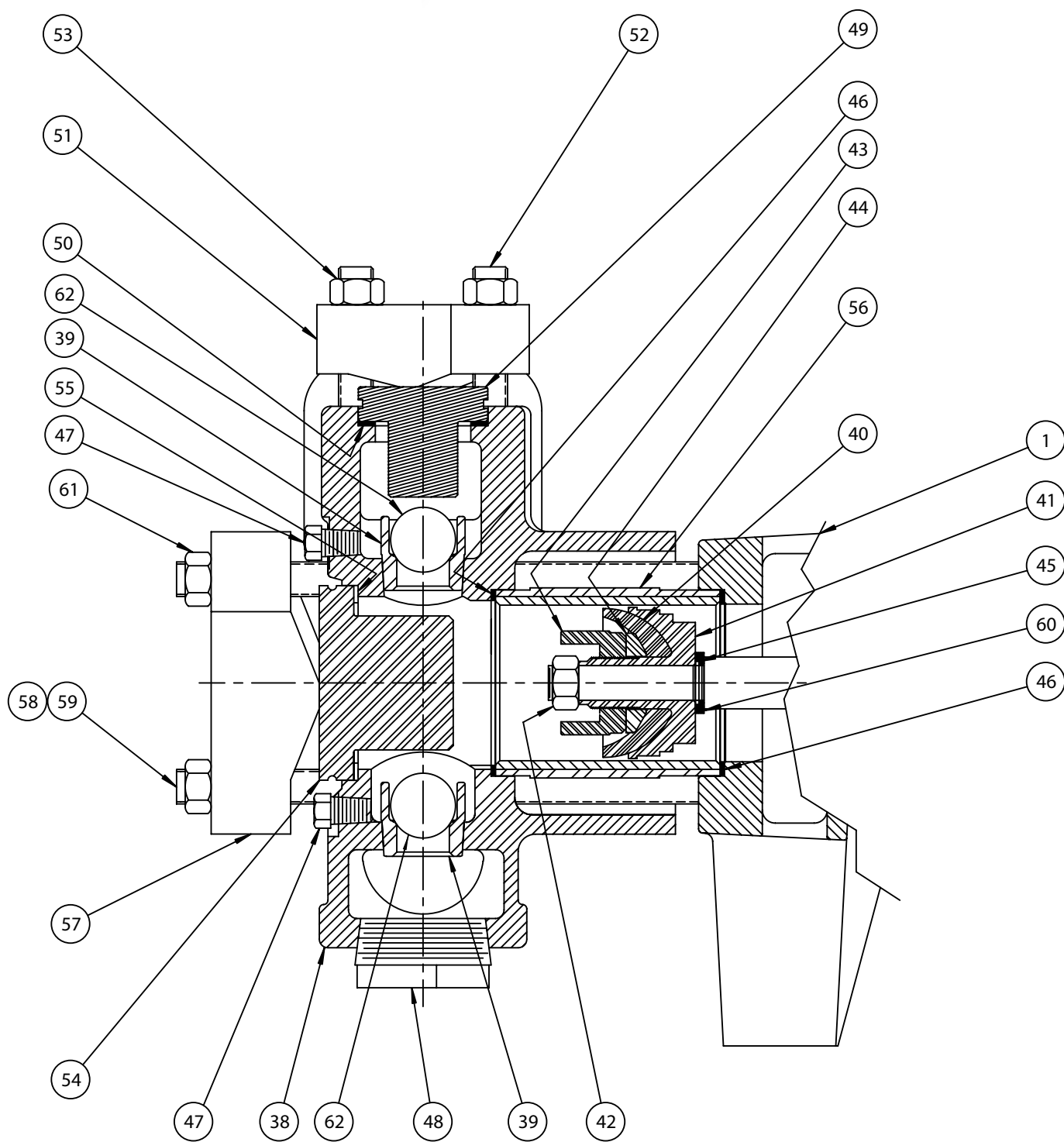

Figure 3: Fluid End Components

## AL0918BCD Component Item Numbers

Item #	Component Description	Part #	Qty	Item #	Component Description	Part #	Qty
1	Power Frame	PPFMC 5260537	1	31	Plate, Inspection	PPFMC 1214260	1
2	Crankshaft	PPFMC 1279071	1	32	Pipe Plug, Power End	PPFMC 1187048	2
3	Pinion Shaft	PPFMC 1265098	1	33	Filler Cap or Vent	PPFMC A5054	1
4	Connecting Rod Assembly	PPFMC 18710	3	34	Screw	PPFMC 1106980	2
5	Rod Bearing	PPFMC P506697	3	38	Fluid Chamber	PPFMC 1255266	1
6	Wrist Pin	PPFMC A5006	3	39	Valve Seat	PPFMC 1225327	6
7	Crosshead Assembly	PPFMC 1250876	3	40	Piston Cup	PPFMC 5260052	3
8	Seal Holder	PPFMC 1283601	3	41	Piston Holder	PPFMC 8495	3
9	Oil Seal, Piston Rod	PPFMC 1283603	6	42	Hex Nut	PPFMC 8309	3
10	Seal Retainer Nut	PPFMC 1283600	3	43	Nut Retainer	PPFMC A5016	3
11	Gasket, Seal Retainer	PPFMC 1283602	3	44	Piston Retainer	PPFMC 1207289	3
12	Bearing Housing, Blind	PPFMC 1279064	2	45	O-Ring, Rod Seal	PPFMC 1101176	3
13	Shim, Bearing Housing	PPFMC 1252594	5	46	Gasket, Fluid Chamber	PPFMC 1280024	6
14	Gasket, Bearing Housing	PPFMC A5025	2	47	Plug, Pipe	PPFMC P501267	6
15	Back Cover	PPFMC 1279063	1	48	Plug, Suction	PPFMC 1105105	2
16	Gasket, Back Cover	PPFMC 1279065	1	49	Valve Cover	PPFMC A5003	3
17	Pinion Housing, Drive	PPFMC A5005	1	50	Gasket, Valve Cover	PPFMC 1280026	3
18	Pinion Housing, Blind	PPFMC 1225769	1	51	Clamp, Valve Cover	PPFMC 1271716	3
19	Petcock	PPFMC 1187039	1	52	Stud, Valve Cover	PPFMC A5012	6
20	Gasket, Pinion	PPFMC A5026	2	53	Hex Nut, Valve Cover	PPFMC 1121511	6
21	Nameplate	PPFMC 5262738	1	54	Cylinder Cover	PPFMC A5002	3
22	Lube Fitting	PPFMC 1100759	3	55	Gasket, Cylinder Cover	PPFMC 1280025	3
23	Bearing Cone, Crank	PPFMC 1101242	2	56	Cylinder	PPFMC 1272060	3
24	Bearing Cup, Crank	PPFMC 1177287	2	57	Clamp, Cylinder	PPFMC 1271415	3
25	Bearing, Pinion	PPFMC 1104444	2	58	Stud, Cylinder Cover	PPFMC A5011	6
26	Key	PPFMC 1187577	1	59	Stud	PPFMC A5009	2
27	Cap Screw, Pinion Bearing	PPFMC 1100068	12	60	Seal Holder	PPFMC 1281655	3
28	Screw	PPFMC 1187413	2	61	Hex, Nut, Cylinder	PPFMC 1121511	8
29	Cap Screw, Back Cover	PPFMC 1106910	14	62	Ball	PPFMC 1101418	6
30	Set Screw	PPFMC 1103470	3				

Table 4: Component Item Numbers

## 9.0 Service Procedures

American Mfg Company pumps are designed to simplify all required maintenance. The following sections illustrate step-by-step instructions for performing the most common service procedures of a pump. Read each section before starting service work on the pump. Refer to Figures 2 and 3 for the location of components.

**WARNING:** Many accidents occur every year through careless use or service of mechanical equipment. You can avoid hazards associated with high-pressure equipment by always following the safety precautions listed in Section 1.0.

**Service Tip –** Press the piston assembly into the liner until the sealing lip has just entered the front of the liner. Use a small amount of glycerin on the ID of the liner to help lubricate the piston during installation. After the liner has been installed in the pump power frame, drive the piston assembly fully to its stop using the American Mfg Company piston tool (PPFMC A5049) and a rubber mallet.

1. It is recommended that a sufficient quantity of clean water be pumped through the fluid end before starting any service procedures that involve fluid end components. This will remove a significant portion of contaminants left in the fluid cylinder by the normal pumpage and improve the ability to work with parts or see potential problems.

2. Bleed off all pressure inside pump fluid end before starting any service work. Shut the valve off on the inlet piping, if provided, to prevent flow of liquid from the source into the pump during service.

**CAUTION:** Check to ensure that the power is locked out and tagged out (motor or engine cannot be started).

3. To service the piston cup seals (40) approximately 2 feet of clearance is required between the front of the pump cylinder cover (54) and any obstructions. If there is insufficient clearance, the pump must be removed and relocated to an area where adequate clearance exists.

**NOTE:** The following tools are available and may be purchased at American Mfg Company's worldwide network of distributors.

Component Description	Part #
Tool, Bearing Press For Pinion	PPAM A000387000
Tool, To Tighten Packing Nut	PPAM A000396000
Tool, Ball Seat Driver	PPAM A000398000
Tool, Ball Magnet	PPAM A000239000
Tool, For Housing Cup Press	PPAM A000401000
Tool, Hand Crank Pinion	PPAM A000402000
Tool, Stud Nut	PPAM A000410000
Tool, Piston Nut Remover	PPFMC A5049

Table 5: Service Tool Item Numbers

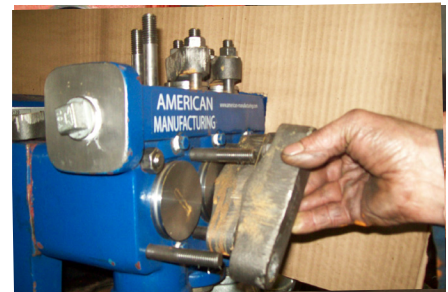

4. To access the piston cup seals (40), the cylinder cover clamps (57) must be removed. Remove six of the nuts (61) holding the cylinder cover clamps (57) in place, and then remove the cylinder covers (54). Do not remove the two nuts (61) on the opposite corners of the fluid cylinder, as they keep the cylinders (56) and fluid cylinder mounted on the pump during this operation. Remove the (55) cylinder cover gaskets.

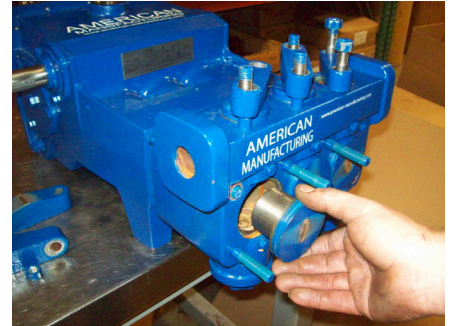

5. Using a socket wrench with a long extension, remove the hex piston nut (42) from the piston/crosshead rod (7). This nut secures the piston assembly to the piston/crosshead rod.

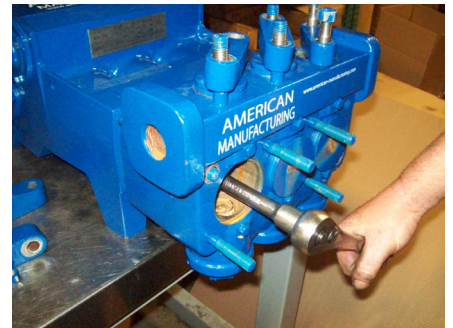

6. Following the hex piston nut (42) removal, use the American Mfg Company piston tool (PPFMC A5049) to pull the piston assembly from the cylinder (56). Insert the American Mfg Company piston tool inside the cylinder until flush with the face of the slotted piston retainer nut (43). Twist the tool to engage and lock the tabs of the tool inside the mating slots in the retainer nut.

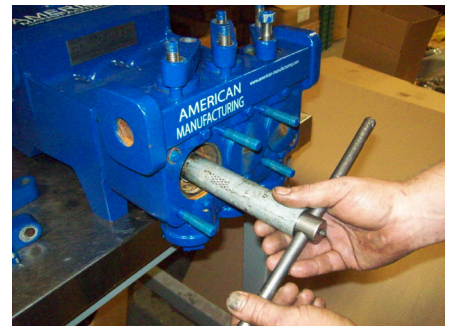

7. Pull the piston assembly free of the pump using a combination pulling and twisting motion.

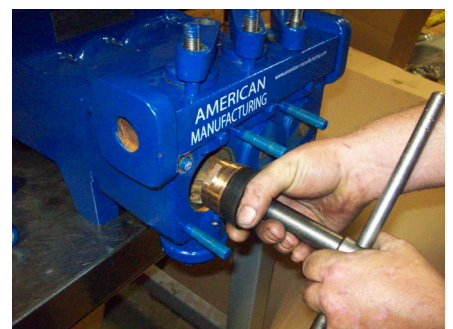



8. Place the flats on the bottom of the piston holder (41) in a vice or clamp securely. Using the American Mfg Company piston tool (PPFMC A5049), unscrew the piston retainer nut (43) and remove. The piston cup (40) and piston retainer (44) may now be removed. Tool PPFMC A5049 is designed with hex nut for using torque wrench to apply proper torque as indicated in 11.0.



9. Inspect all parts for damage or unusual wear. Ensure that the interior surface of the cylinder (56) is smooth and free of cracks or grooves. New piston cups (40) will fail prematurely if installed in liners with damaged bores. American Mfg Company strongly recommends that all three piston cups be replaced, not just those that show signs of leakage, whenever this type of service is performed. This will maximize operational time between service intervals.

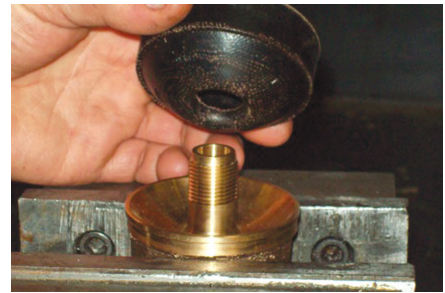

10. Reverse steps 3 through 9 to rebuild the pump after worn or damaged components have been replaced. American Mfg Company recommends that all seals and gaskets that are disturbed during the service procedures be replaced. This includes the rod seal o-ring (45) that is located on the piston/crosshead rod (shown) directly behind the piston assembly. Some pump models have the o-ring in a groove in the piston holder instead of a separate seal holder. Lubricate the piston cups and piston rods during assembly.

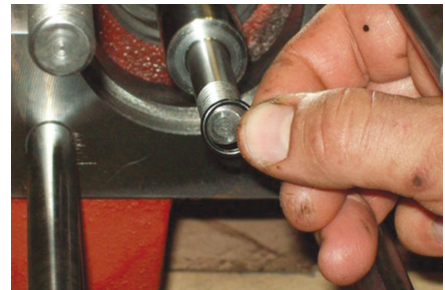

11. Tighten all fasteners to the values specified in Fastener Torque Requirements, Section 11.0 of this manual.

## 9.1 Removing the Fluid Cylinder

**NOTE:** The fluid chamber (56) may be removed to inspect for internal damage, to be repaired, to replace the fluid cylinder, to replace damaged cylinders, cylinder o-rings, or to service piston rod seals.

Refer to Figure 3 for illustration of parts.

1. It is recommended that a sufficient quantity of clean water be pumped through the fluid end before starting any service procedures that involve fluid end components. This action will remove a significant portion of contaminants left in the fluid cylinder by the normal pumpage and improve the ability to work with parts or see potential problems.

2. Bleed off all pressure inside pump fluid end before starting any service work. Shut the valve on the inlet piping if provided to prevent flow of liquid from the source into the pump during service.

**CAUTION:** Check to ensure that the power is locked out and tagged out

3. Remove the cylinder cover clamps (57) and cylinder covers (54) as described in the previous section. Remove the outside corner fluid chamber nuts (61) if they are still in place.

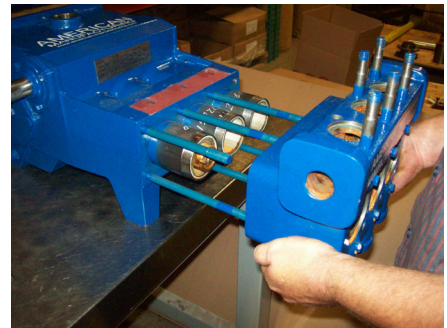

4. Rock the fluid cylinder (fluid chamber) to loosen from the cylinders (liners) (56), and pull free of the fluid end studs. If the pistons have already been removed, take care to ensure that the cylinders (liners) do not fall off of the front of the power end and become damaged.

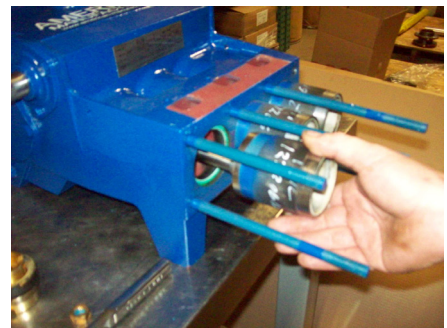

5. To remove the piston assemblies, refer to the previous section (9.0).

6. Inspect all parts for signs of wear or damage. Replace parts if required.

7. Always replace the cylinder gaskets (46) when the cylinders have been moved or replaced.

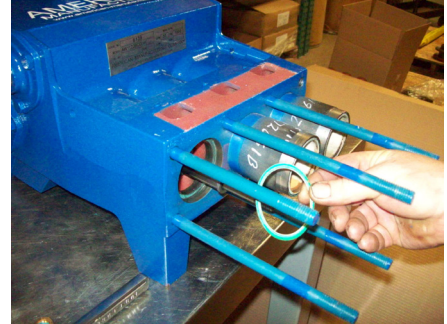

8. Installation will be the reverse of this procedure.

9. Torque all fasteners as outlined in the Fastener Torque Requirements, Section 11.0 of this manual. Please note that if the nuts (61) on the fluid cylinder studs (58 and 59) are not properly torqued, a failure is likely.

## 9.2 Replacing Valves

1. Ball type valves are supplied with the AL0918BCD pump.

2. A minimum of approximately 2 feet of clearance is required above, below, and in front of the pump fluid cylinder to allow valve service without removal of the fluid end. If sufficient clearance is not available, the fluid end must be removed as outlined in previous section (9.1) and taken to a work shop for valve service. The following procedure is written under the assumption that sufficient clearances exist.

3. Remove the three suction plugs (48) from the bottom of the fluid chamber (38).

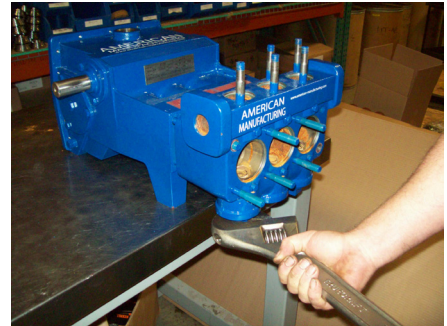

4. Remove the six valve cover nuts (53) holding the valve cover clamps (51) and then remove the three valve covers (49) from the fluid cylinder.

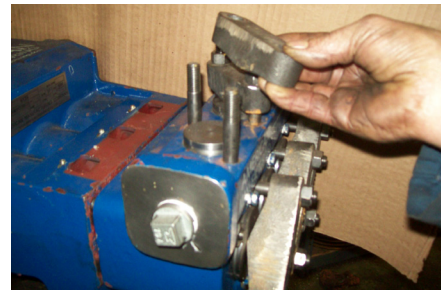

5. The cylinder covers (54) allow access for inlet valve removal. Remove the cylinder covers as described in section 9.1, steps 1 through 9.





6. For ball valves, the balls are not retained in the valve seat. The ball can easily be removed from the valve assembly by lifting it out of the open cage portion of the valve seat with American Mfg Company tool PPAM A000239000. Then remove the valve seat from the fluid chamber.



7. To remove the valve seat use knock out tool PPAM A000398000. This tool is inserted from the bottom of the fluid cylinder. The tool has a step at the end that mates with the valve seat. The tool is then struck sharply with a hammer and the valve is loosened. The suction valve seats can be removed first through the cylinder cover. The discharge valve seats can be removed through the valve covers.

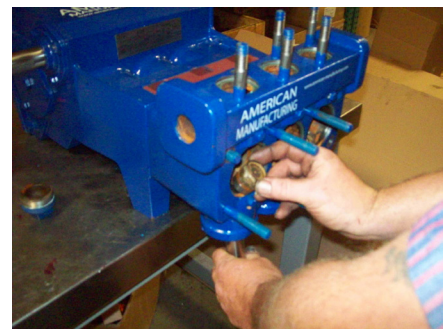
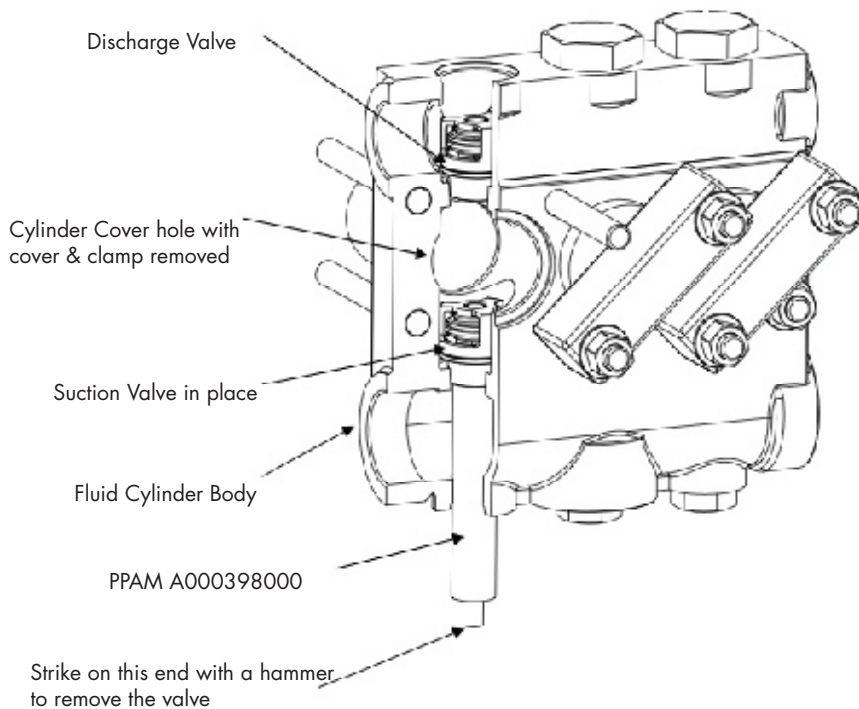

Figure 4: Using the Knock Out Tool

## 8. Installation of Ball Valve Seats

The suction valve seats must be installed before the discharge valve seats can be installed. The following re-assembly procedure is applicable for both.

- A. Select a new valve seat and check to ensure the taper on the seat is clean.
- B. Carefully clean the taper in the fluid cylinder and on the seat with a cleaning solution and a clean cloth. Small scratches can be removed with steel wool or 100 grit emery paper. Remove all dirt, grease, oil, water, or any other contaminants from the surfaces. Do not oil the seats or the seating surfaces in the fluid cylinder. Confirm that they are dry before installation.
- C. Position the valve seat directly over the mating taper in the fluid cylinder.
- D. Let the valve seat drop into the taper. Check to see that the seat is sitting in the taper properly and not cocked to one side. If the seat drops straight, it will seize on the taper. When correctly seated, it cannot be pulled up by hand.
- E. Use tool PPAM A000398000 to install the valve seats. Place the tool on the top surface of the valve seat. Strike with a hammer three times to set the valve seat.
- F. Repeat steps A through E for the discharge valves.

9. After the valves have been replaced, American Mfg Company recommends that the valve cover be replaced. Install the valve cover with the new gasket (50) in place, and install the valve cover clamps (51) over the valve cover studs (52). Replace valve cover and valve cover hex nuts (53).

10. Torque the valve cover hex nuts or hex plugs to the recommend values listed in the Fastener Torque Requirements, Section 11.0, of this manual.

## 10.0 Servicing the Power End

### 10.1 Replacing Piston Rod Oil Seals

**NOTE:** Ensure that all pressure inside the pump fluid cylinder has been bled off before starting any service work.

**CAUTION:** Check to ensure that the power is locked out and tagged out

The piston rod oil seals (9) retain oil in the power end and prevent contamination from entering the power end by way of the piston rods. The fluid end and cylinders must be removed as outlined in the previous sections to provide access to these seals.

1. Rotate the seal retainer (10) counter clockwise until it is unscrewed from the frame, then slide off the rod. Use a larger flat head screw driver as shown or use tool PPAM A000396000.

2. Pull the seal holder (8) out of the pump frame and slide off of the rod. It may be necessary to insert a screwdriver or pointed tool into one of the holes in the seal holder to help extract it from the power frame.

3. Remove the seal retainer gasket (11) from the power frame. Inspect the seals (9) and note the orientation of the seals prior to removal. The seals may now be removed from the seal holder and discarded.

4. To rebuild, insert new seals (9) in the seal holder (8), taking care to ensure they are oriented in the same manner as the ones that were removed. Do not reuse seals that have been removed from the pump. Replace the seal retainer gasket (11) if it shows signs of deformation or damage.

5. Wrap tape or other material over the exposed piston rod threads to protect the new seal lips from damage. Install the seal retainer gasket then slide the seal holder over the protected threads and into the pump frame. Care must be taken to ensure the seal lips are not folded or cut when passing over the ends of the rod.

6. Ensure that the gasket (11) and seal holder (8) are in place, install the seal retainer (10) and tighten until it bottoms out. Do not over tighten as it can damage the seal retainer gasket.

7. Remove the protective material that is covering the rod threads. Rebuild the remainder of the pump as outlined in previous sections. Torque all fasteners as outlined in the Fastener Torque Requirements, Section 11.0, of this manual.

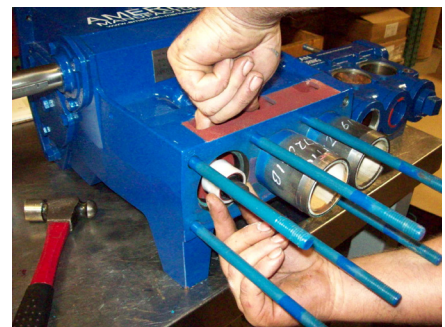



## 10.2 Replacing Power End Bearings & Crankshaft

**WARNING:** Disconnect the driver from the pump and ensure that suction and discharge lines are disconnected or blocked and have no pressure applied.

1. Removal of the fluid cylinder simplifies crankshaft removal on AL0918BCD models.
2. Remove magnetic pipe plug (32) to allow all oil to drain from power frame (1).
3. Remove all rear cover cap screws (29). Remove the back cover (15) and back cover gasket (16) from the power frame.



4. Remove the end cap of each connecting rod (4) by unscrewing the two hex nuts that hold each cap to the connecting rod body. The cap can be removed from the body by tapping with a rubber mallet on the cap screws to remove them and then tapping on the end cap to loosen it. Take care to not damage the threads on the cap screws.

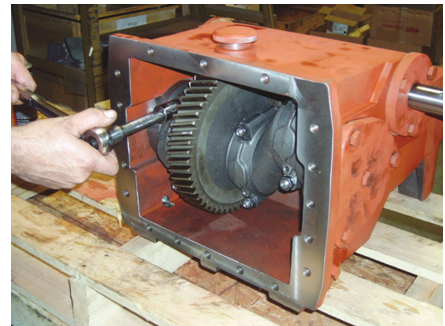

5. Slide the two rod bearing halves (5) from each connecting rod (4). Note that these parts sometimes adhere to the pins (journals) on the crankshaft (2).

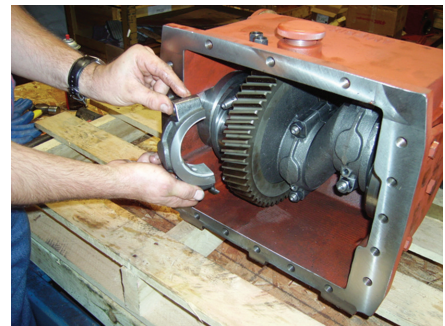

6. **NOTE:** Connecting rods and caps are matched sets and must always be re-assembled with their original mate and in the same orientation. Note the numbered codes stamped on each half of the connecting rod assemblies and make certain they are installed as matched set and in the same orientation when re-assembling the pump.



The AL0918BCD pumps are configured with pinion shafts for internal gear reduction.

7. For AL0918BCD pumps with the pinion shaft, remove the hex head cap screws (27), the left and right pinion housings (17 and 18). The gaskets (20) may adhere to the power frame surface and can be left in place if they are not damaged.

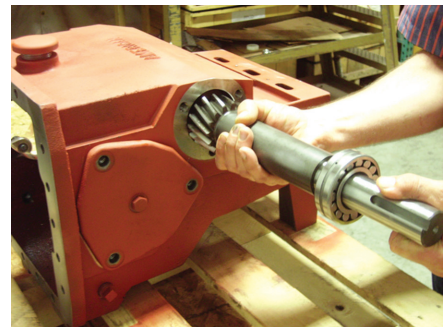

8. The pinion shaft (3) with bearings may then be removed from the drive side by using a brass rod (or other soft material) and mallet to drive the shaft out.

**Installation Tip:** Mark the bearing housings and power frame for installation in the original position.

9. Remove the hex head cap screws (27), bearing housings (12) gaskets (14) and shims (13) from both sides of the pump. Count and record the shims on each side to facilitate assembly. The gaskets (14) may adhere to the power frame surface and can be left in place if they are not damaged. The bearing cones (23) will remain in the bearing housing.

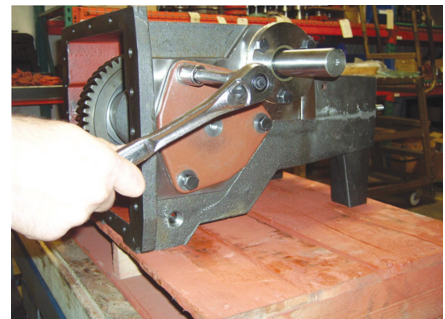

10. To remove the crankshaft on AL0918BCD models work the crankshaft to the left when viewing from the rear opening of the power frame. The throws or journals may have to be rotated as the crank is removed to clear the connecting rods. Slip the crankshaft end on the right out the back of the power frame and remove. The crankshaft should be handled carefully to prevent the critical bearing surfaces from being scratched or damaged.



11. Bearing cups (24) may be removed from the crankshaft. Bearing cones (23) can be removed from the bearing housing using a puller if a sufficient lip is available for the puller arms to grab. An alternate procedure involves running a weld bead around the inside surface of the cup. When cool, this will reduce the interference between the cup and bearing housing enough to free the cup. If either the cup or cone is replaced, the corresponding cup or cone should be replaced as they are a matched set. Tool PPAM A000401000 can be purchased to press bearing cones (23) into bearing housing.

12. Pull the connecting rod/crosshead assemblies (7) from the power frame. Mark each connecting rod and crosshead assembly to ensure they are reassembled into the same bore from which they were removed.

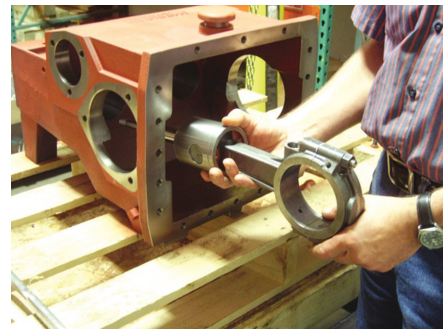

13. Remove the set screw (30) and slide the wrist pin (6) out of the crosshead (7) if crosshead or connecting rod (4) requires service. Keep components matched together.

14. Inspect all components for signs of wear or damage and replace if required. Carefully check the crankshaft bearing surfaces for pits, scratches, or other signs of wear. The connecting rod bearings should be inspected for deep scratches or the top metal surface worn away.

15. Thoroughly clean all parts with solvent and apply a thin coat of oil before reassembly.

16. Tapered roller bearing cups (24) must be heated to aid in assembly onto the shaft. Always observe proper safety procedures and use heat resistant tools and gloves when handling hot parts. There are a number of recommended methods for heating bearings. Electric ovens or electrically heated oil baths may be used, but only when accompanied by proper thermostatic control.

17. To replace the tapered roller bearings on the crankshaft, heat the cones to a maximum of 300° F (149° C). Slide them down the shaft unit they are fully seated against the shoulder. The hot cup may pull away from the shoulder unless it is held in position until it cools enough to grab the shaft. Use a .001" thick feeler gauge to ensure the cone is fully seated against the shoulder after the parts have cooled.

18. Use a press to seat the new cones (23) into the bearing housings. Never use new bearing cups with old bearing cones. Always use matched sets from one manufacturer.

19. Reassemble the crosshead assemblies and connecting rods. Ensure that the set screws (30) retaining the wrist pin (6) are in place. The set screw must engage the flat on the wrist pin. Refer to Section 11.0 for torque specifications.

20. Push the crosshead/connecting rod assemblies fully forward in power frame to provide maximum clearance for the crankshaft. Ensure crosshead assemblies are replaced in the same orientation and in the same cylinder bore they were originally.

**NOTE:** The oil cup pocket feeds lubricant to the wrist pin bushing. This is located on the top of the connecting rod and should be in the up position.

21. Install crankshaft in the power frame. Take care not to scratch the bearing surfaces of the crankshaft.

22. Inspect the gasket (14) that seals the bearing housing and replace if damaged. Reinstall the shims (13) and bearing housings (12). As a starting point, install the same number of shims that the pump originally had prior to service work. When tightening the fasteners retaining the bearing cover, use a crisscross pattern for tightening with a torque wrench.

23. Replace the rod bearings (5) in the connecting rod and connecting rod caps. Ensure that rod caps are properly assembled with their mating connecting rod. Torque the fasteners holding the end caps to the mating rod per the values given in Fastener Torque Requirements, Section 11.0 of this manual. Use back and forth pattern tightening with a torque wrench. After the cap screws are torqued, a light strike to the cap with a rubber hammer will help properly seat the rod bearings.

24. A dial indicator must be used to properly adjust the endplay of the crankshaft. Improper adjustment may result in excessive temperature, noise, and reduced bearing life. American Mfg Company recommends between .002" tight to .003" loose of internal axial clearance (end play) when properly assembled. The final adjustment must be verified using a dial indicator as indicated in the following steps 29 through 32.

25. Turn the crankshaft at least two (2) revolutions to ensure the connecting rods (4) are loose and that there is no binding in the rod bearings (5), the wrist pin (6) joints are free, and the crossheads move freely in the power frame (1). Tool PPAM A000402000 may be purchased to help turn the crankshaft



26. Move the crankshaft to one side of the power frame using a light tap from a rubber mallet or a pry bar. Rotate the crankshaft several turns and repeat the light taps from a rubber mallet or the use of a pry bar to ensure the crankshaft is to one side.

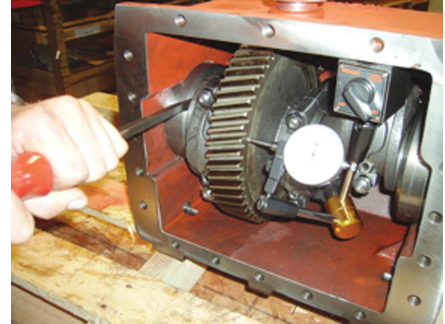

27. Mount indicator base on the power frame with the indicator tip on a machined shoulder surface of the crankshaft (do not measure from a cast surface) and the axis of the indicator parallel to the crankshaft.



28. Set the dial indicator to zero.

29. Move the crankshaft back over to the opposite side and read the bearing end play as total indicator movement. Rotate the crankshaft several turns, then repeat moving the crankshaft in the direction described in this step. Repeat the dial indicator measurement. Remove or add shims as necessary to achieve proper endplay (.002" tight to .003" loose). Distribute shims equally on both bearing housings. Verify the endplay with the dial indicator per this procedure described before final assembly.

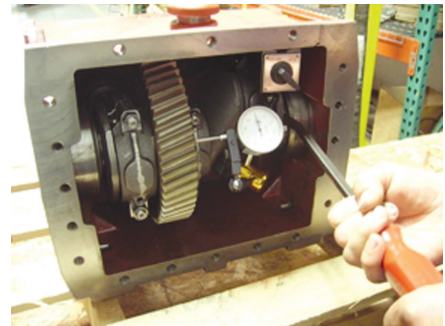

30. Install the piston rod seal holder (9) and seal retainer (8) in the power frame per instructions in section 10.1. The crankshaft should turn freely.

31. Complete reassembly of pump. Tool PPAM A000387000 can be purchased to aid in the assembly of the pinion bearing if needed.

32. Torque all fasteners as outlined in Fastener Torque Requirements, Section 11.0 of this manual.

## 11.0 Fastener Torque Requirements

**NOTICE:** No pump service procedure is complete without applying the proper fastener torque. Failure to properly tighten the pump bolts could cause the pump to leak or possibly allow the pump to fail. Always use a calibrated torque wrench during the installation of all critical fasteners listed in Table 6 below. Values are in foot-pounds (Ft-lb) and Newton meters (N-m). Typical sizes are shown in Table 6 below. Refer to Table 7 for other sizes that may be used depending on application.

### Power End Torque Values

Item #	Component Description	Size	Ft-lb	(N-m)
4	Connecting Rod Bolts	.438 (7/16)	45	61
43	Piston Assembly Nut	.750 (3/4)	35	47
42	Piston Rod Hex Nut	.500 (1/2)	35	47
28	Bearing Housing Screws	.375 (3/8)	25	34
28	Pinion Housing Screws	.375 (3/8)	25	34
29	Back Cover Bolts	.375 (3/8)	20	27
27	Cross Head Set Screw	.313 (5/16)	10	14
61	Cylinder Attach/Clamp Nut	.500 (1/2)	75	102
53	Valve Cover Nut	.500 (1/2)	60	81

Table 6: Torque Values for Critical Pump Fasteners

## 12.0 Critical Clearances

When maintenance requiring disassembly of the power end is performed, the following clearances should be checked to see if they are within factory specification or within maximum allowable limits. Additional clearance is allowed for component wear. This additional clearance is a maximum of .002 inches of total diametral wear that can be added to the clearance values in Table 7. For radial clearance, use ½ of the total diametral value. All dimensions are shown in inches.

Description	Clearance
Crankshaft Throw Diameter (Stroke)	2.25
Crankshaft Pin or Journal (OD)	2.8743/2.8748
Connecting Rod / Crank Clearance (Max. Total)	.003
Crosshead Diameter (OD)	2.749/2.750
Crosshead Cylinder Bore (ID)	2.7515/2.7535
Crosshead to Bore Clearance (Max. Total)	.0045
Wrist Pin Bushing Bore (ID)	1.0005/1.0015
Wrist Pin to Bore Clearance (Max. Total)	.002

Table 7: Clearance Chart

**Metric Conversion:** 1 inch = 25.4 mm  
1 mm = 0.03937 inches

**NOTE:** Clearances shown are total diametral values: For radial clearance use ½ the value shown.



## 13.0 Trouble-Shooting Pumps

This chart is designed to aid in the solution of pump and pump system problems. Once the problem has been identified, work through the possible causes and solutions until the problem has been corrected.

Symptom	Possible Cause	Possible Solution
No flow from pump	<ul style="list-style-type: none"> <li>No liquid in reservoir (tank)</li> <li>Inlet line valve closed</li> <li>Inlet strainer is totally clogged with debris</li> <li>Crankshaft is not turning</li> </ul>	<ul style="list-style-type: none"> <li>Ensure lines are connected and fill tank</li> <li>Ensure lines are connected and open valve</li> <li>Clean or replace strainer</li> <li>Check for power to drive and drive connections</li> </ul>
Insufficient pressure from pump (ONLY)	<ul style="list-style-type: none"> <li>Pump speed is too low</li> <li>Relief valve improperly adjusted or worn</li> <li>Insufficient system resistance (worn nozzle)</li> <li>Worn check valves</li> <li>Excessive leakage from pump seals</li> </ul>	<ul style="list-style-type: none"> <li>Check belt tightness or power to motor</li> <li>Check relief valve and adjust setting</li> <li>Properly service system</li> <li>Inspect check valves and repair or replace</li> <li>Adjust or replace packing or damaged parts</li> </ul>
Insufficient flow from pump (ONLY)	<ul style="list-style-type: none"> <li>Pump speed is too low</li> <li>Relief valve improperly adjusted or worn</li> <li>Worn pump valves</li> <li>Excessive leakage from pump seals</li> <li>Plunger or piston worn</li> <li>Valve seat washed out in fluid cylinder</li> </ul>	<ul style="list-style-type: none"> <li>Check belt tightness or power to motor</li> <li>Check relief valve and adjust setting</li> <li>Inspect pump valves and repair or replace</li> <li>Adjust or replace packing or damaged parts</li> <li>Replace plunger or piston</li> <li>Repair or replace fluid cylinder</li> </ul>
Insufficient flow or pressure AND rough operation (pump pounds or vibrates)	<ul style="list-style-type: none"> <li>All pump cylinders not primed</li> <li>By-pass or relief is piped back to suction</li> <li>Inlet line too long or too small in diameter</li> <li>Insufficient NPSHA</li> <li>Air leaks in suction line or fittings</li> <li>Vortex in tank near inlet pipe opening</li> <li>Air entering booster pump</li> <li>Pump valve stuck open or closed</li> <li>Valve assembly damaged or unseated</li> <li>Valve seat washed out in fluid cylinder</li> <li>Gas pocket formation from high spots in suction</li> </ul>	<ul style="list-style-type: none"> <li>Prime all chambers</li> <li>Pipe back to reservoir (tank)</li> <li>Increase suction pipe size</li> <li>Provide more NPSH</li> <li>Correct installation to stop leaks</li> <li>Increase submergence or baffle to stop vortex</li> <li>Correct installation of booster pump</li> <li>Clean and deburr valve</li> <li>Properly seat or repair valve</li> <li>Repair or replace fluid cylinder</li> <li>Correct suction line installation</li> </ul>

Symptom	Possible Cause	Possible Solution
Pump runs rough, knocks, or vibrates (ONLY)	<ul style="list-style-type: none"> <li>• Broken or weak valve spring</li> <li>• Valve damaged or unseated</li> <li>• Loose plunger, piston, or rod</li> <li>• Low oil level in power end</li> <li>• Excessive connecting rod brg clearance</li> <li>• Excessive main bearing clearance</li> <li>• Worn wrist pin or bearing</li> <li>• Pump running backward</li> <li>• Loose sheaves or bushings (v-belt drive)</li> <li>• Gear tooth cracked or broken</li> <li>• Insufficient NPSHA</li> <li>• Excessive acceleration head in suction line</li> <li>• Pulsation dampener improperly charged</li> <li>• Inlet line too long or too small in diameter</li> <li>• Worn piston seal allows air ingress (usually observed when booster not used)</li> </ul>	<ul style="list-style-type: none"> <li>• Replace valve spring</li> <li>• Repair/replace valve or re-seat</li> <li>• Tighten loose components</li> <li>• Fill to proper level</li> <li>• Check cap torque or replace bearings</li> <li>• Adjust end-play</li> <li>• Replace worn components</li> <li>• Correct rotation</li> <li>• Tighten loose components</li> <li>• Replace gear</li> <li>• Provide more NPSH</li> <li>• Install suction stabilizer</li> <li>• Charge to proper pressure</li> <li>• Increase suction pipe size</li> <li>• Replace piston seal</li> </ul>
Rapid suction pressure fluctuation	<ul style="list-style-type: none"> <li>• Pump cavitation</li> <li>• Air is entering suction line</li> </ul>	<ul style="list-style-type: none"> <li>• Increase suction size or NPSH</li> <li>• Correct installation to stop leaks</li> </ul>
Piping vibration	<ul style="list-style-type: none"> <li>• Same as Pump runs rough above</li> <li>• Excessive pressure variation in discharge</li> <li>• Piping inadequately supported</li> <li>• Excessive short-radius elbows or tees</li> </ul>	<ul style="list-style-type: none"> <li>• See above</li> <li>• Install discharge pulsation dampener</li> <li>• Install supports at proper locations</li> <li>• Correct installation to minimize turns and short-radius fittings</li> </ul>
Pump requires excessive power	<ul style="list-style-type: none"> <li>• Discharge pressure too high</li> <li>• Plungers or pistons too large</li> <li>• Speed too high</li> <li>• Packing too tight</li> <li>• Misaligned coupling</li> <li>• Belts too tight</li> <li>• Power end bearings too tight</li> <li>• Low motor voltage</li> </ul>	<ul style="list-style-type: none"> <li>• Reduce system back-pressure or adjust relief valve</li> <li>• Install smaller plungers to reduce flow</li> <li>• Reduce speed</li> <li>• Loosen gland (Adjustable packing)</li> <li>• Correct alignment</li> <li>• Correctly adjust belt tension</li> <li>• Increase end-play</li> <li>• Supply correct voltage</li> </ul>

Symptom	Possible Cause	Possible Solution
Power end overheats (over 180° F) and/or reduced power component end life	<ul style="list-style-type: none"> <li>• Discharge and/or suction pressure too high</li> <li>• Oil level too high or too low</li> <li>• Contaminated power end oil</li> <li>• Incorrect oil viscosity or grade</li> <li>• Misaligned coupling</li> <li>• Belts too tight</li> <li>• Pump running backward</li> <li>• Pump located too close to heat source</li> <li>• Worn or damaged power end bearings</li> </ul>	<ul style="list-style-type: none"> <li>• Reduce pressure or reduce plunger size</li> <li>• Adjust to correct oil level</li> <li>• Refill with clean oil &amp; eliminate contamination</li> <li>• Fill with correct oil</li> <li>• Correct alignment</li> <li>• Correctly adjust belt tension</li> <li>• Correct rotation</li> <li>• Remove heat source or insulate power end</li> <li>• Replace damaged bearings</li> </ul>
Crankshaft jerks or starts and stops rotation	<ul style="list-style-type: none"> <li>• Drive belts loose and slipping (if equipped)</li> <li>• System relief valve pressure set too high</li> <li>• Discharge line blocked or partially blocked</li> </ul>	<ul style="list-style-type: none"> <li>• Correctly adjust belt tension</li> <li>• Reduce relief valve pressure setting</li> <li>• Clear obstructions from piping system</li> </ul>
Fluid leaking from pump	<ul style="list-style-type: none"> <li>• Piston cups are worn</li> <li>• Piston to rod o-ring damaged</li> <li>• Fluid cylinder bolts not properly tightened</li> <li>• Fluid cylinder o-rings (or gaskets) damaged</li> </ul>	<ul style="list-style-type: none"> <li>• Replace piston cup</li> <li>• Replace o-ring</li> <li>• Properly tighten and torque bolts</li> <li>• Replace damaged o-rings or gaskets</li> </ul>
Reduced packing or piston cup life	<ul style="list-style-type: none"> <li>• Highly abrasive particles in fluid</li> <li>• Packing or piston cups run dry</li> <li>• Incorrect packing or cups for fluid type</li> <li>• Inadequate packing lubrication</li> <li>• Pump was run dry for extended time</li> <li>• Plunger (or rod) misaligned to stuffing box</li> <li>• Worn plunger or cup holder</li> <li>• Worn cylinder liner bore</li> <li>• Packing gland too tight (adjustable)</li> <li>• Packing gland too loose (adjustable)</li> <li>• Too much packing in box</li> <li>• Broken or weak spring</li> </ul>	<ul style="list-style-type: none"> <li>• Install strainer or filter</li> <li>• Correct problem &amp; replace packing or cup</li> <li>• Change to correct packing or cup</li> <li>• Correct problem and replace packing</li> <li>• Correct problem and replace cups</li> <li>• Correct alignment</li> <li>• Replace plunger or cup holder</li> <li>• Replace cylinder liner</li> <li>• Properly adjust gland nut</li> <li>• Properly adjust gland nut</li> <li>• Correct installation problem</li> <li>• Replace spring</li> </ul>
Reduced valve life	<ul style="list-style-type: none"> <li>• Highly abrasive particles in fluid</li> <li>• Cavitation damage</li> <li>• Air leaking into suction line or stuffing box</li> <li>• Suction inlet insufficiently submerged</li> <li>• Relief valve or bypass piped to suction</li> <li>• Valve damaged by improper installation</li> </ul>	<ul style="list-style-type: none"> <li>• Install strainer or filter</li> <li>• Correct problem and replace damaged valves</li> <li>• Correct problem and replace damaged valves</li> <li>• Increase submergence or baffle to stop vortex</li> <li>• Pipe back to reservoir (tank)</li> <li>• Replace damaged components</li> </ul>

Symptom	Possible Cause	Possible Solution
Cracked fluid cylinder or broken fluid end bolts	<ul style="list-style-type: none"> <li>• Discharge pressure too high</li> <li>• Hydraulic shock (cavitation or entrained air)</li> <li>• Discharge valve stuck closed</li> <li>• Fluid freezing in fluid cylinder</li> <li>• Material or manufacturing defect</li> <li>• Bolt or nut not properly torqued</li> <li>• Excessive piping loads on fluid end</li> </ul>	<ul style="list-style-type: none"> <li>• Reduce system back pressure or relief valve</li> <li>• Correct piping system problem</li> <li>• Replace damaged components</li> <li>• Change procedure to drain fluid when cold</li> <li>• Replace defective component</li> <li>• Replace fluid cylinder and properly torque</li> <li>• Add supports to piping</li> </ul>
Broken crankshaft or connecting rod	<ul style="list-style-type: none"> <li>• Discharge pressure too high</li> <li>• Suction pressure too high</li> <li>• Fluid freezing in fluid end</li> <li>• Hydraulic shock due to cavitation</li> <li>• Material or manufacturing defect</li> </ul>	<ul style="list-style-type: none"> <li>• Reduce system back pressure or relief valve</li> <li>• Reduce suction pressure or plunger diameter</li> <li>• Change procedure to drain fluid when cold</li> <li>• Correct piping system problems</li> <li>• Replace defective components</li> </ul>
Power end oil is contaminated	<ul style="list-style-type: none"> <li>• Extended operation with failed piston cup</li> <li>• Hi-pressure sprayer nozzle near breather or seals</li> <li>• Deflector shields are missing or damaged</li> <li>• Crosshead extension seals damaged</li> <li>• Excessive capacity in liner wash system</li> <li>• Improperly adjusted liner wash nozzle</li> </ul>	<ul style="list-style-type: none"> <li>• Replace piston cup and improve monitoring</li> <li>• Provide shields to protect breather and seals</li> <li>• Repair or replace deflector shields</li> <li>• Replace oil seals</li> <li>• Reduce capacity in liner wash system</li> <li>• Adjust liner wash nozzle</li> </ul>

## 14.0 Ordering Parts

Service parts are available through American Mfg Company 's worldwide network of distributors or from the original supplier. If unsure where to purchase parts, contact American Mfg Company customer service for the location of an authorized parts retailer in your area.

Always insist on genuine American Mfg Company replacement parts.

Use the assembly drawing and bill of material included on pages 17 through 20 with this manual to determine the components and corresponding part numbers required to service the pump. Make sure that the model number on the drawing or bill of material matches the model number of the pump requiring parts.

When ordering parts, always reference the model number of the pump with the order. These numbers can be found stamped on the metal name tag affixed to the power end of every pump. By referencing these numbers you can ensure that the components you receive work as intended with your pump. Be sure to inquire about any special service tools or complete maintenance kits.

## 15.0 Additional Pump Assembly Products

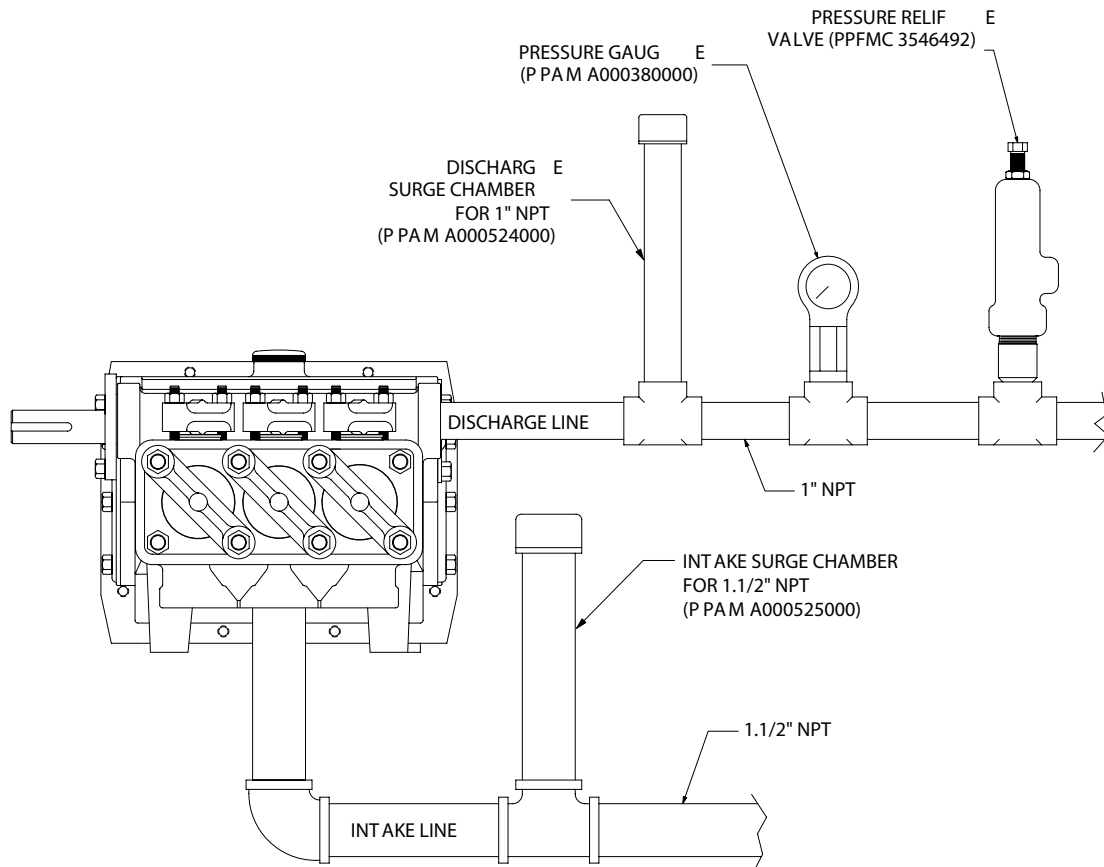

Figure 5: Additional Pump Assembly Product Item Numbers

### Replacement Rubbers

Component Description	Part #
Piston Rubber 2-1/4 (Carbox Nitrile XNBR)	PPFMC 5260052

### Alternates

Component Description	Part #
Piston Rubber 2-1/4 (Neoprene)	PPFMC A3434N
Piston Rubber 2-1/4 (HSN)	PPFMC P513766

Table 8: Replacement Rubber Item Numbers

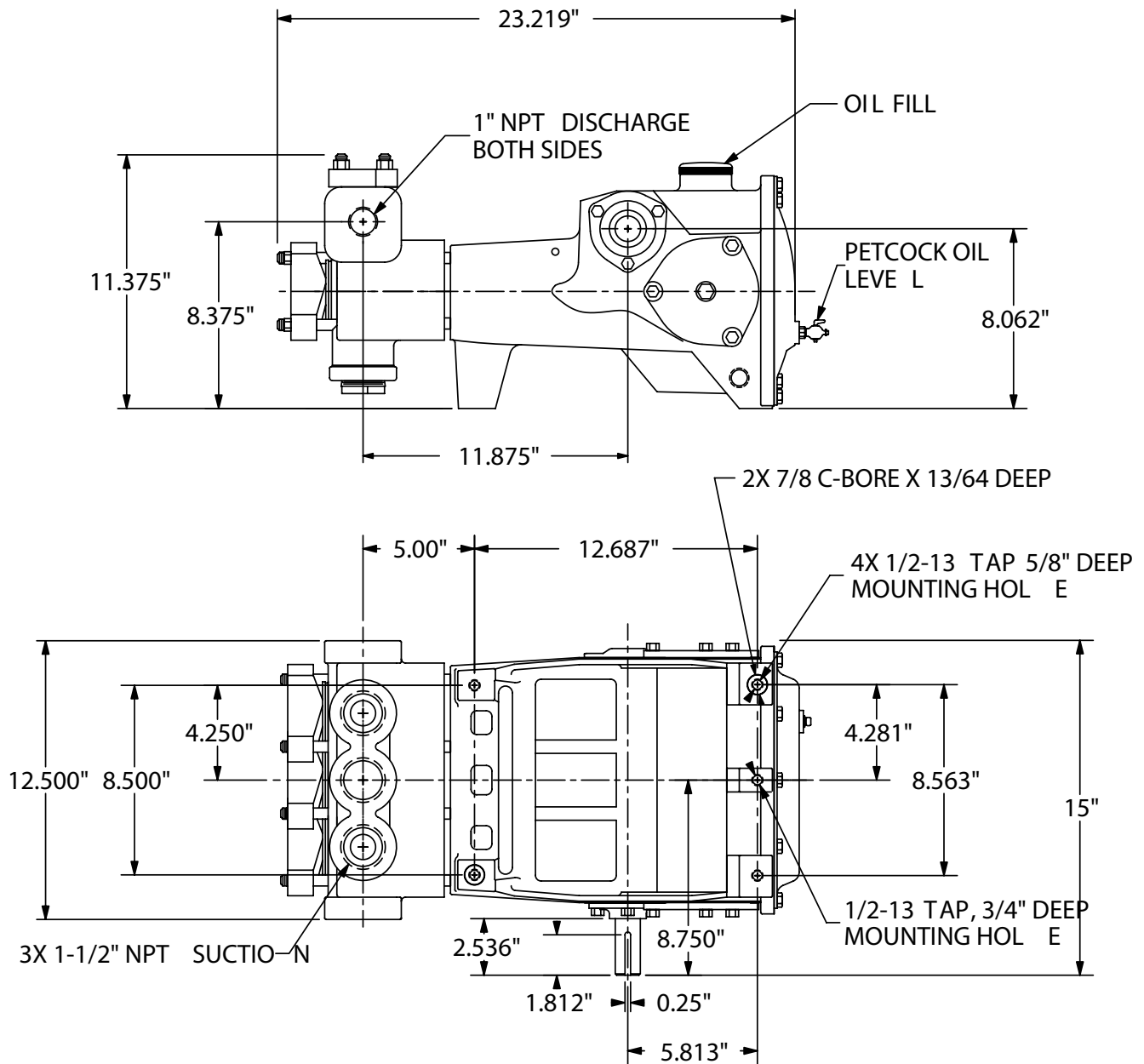

Figure 6: Pump Mount Bolt Pattern



## 16.0 Glossary of Commonly Used Terms

**CAPACITY** – The total volume throughput per unit of time at suction conditions. It includes both liquid and any dissolved or entrained gases. For all practical purposes this can be considered the volume flow rate in the suction pipe. The standard unit of pump capacity is U.S. gallons per minute (GPM) and metric cubic meters per hour (m<sup>3</sup>/hr).

**CAVITATION** – The state where fluid pressure drops below vapor pressure, causing the liquid to begin to change from a liquid to a gas and boil. Usually occurs in the chamber between the suction and discharge valves during the suction stroke, and often sounds like a mechanical knock. Cavitation results in the formation of gas bubbles, or cavities, in the fluid that cause vibration and damage to components when they collapse.

**DAMPENER** – A device that reduces pressure pulsations in the suction or discharge piping. This may be referred to as a suction stabilizer, accumulator, or surge suppressor.

**DISPLACEMENT** – The volume swept by all pistons or plungers per unit time. This term is typically expressed as gallons per revolution.

**FLOODED SUCTION** – Implies that the level of liquid in the suction vessel is above the centerline of the suction port of the pump.

**FLUID END** – The portion of the pump that converts the linear motion supplied by the power end into fluid flow at pressure. This may also be called the Liquid End. It is called a valve chamber in old literature.

**MECHANICAL EFFICIENCY** – Mechanical efficiency (ME) is the ratio, expressed as a percentage, of pump power output to the pump power input. The mechanical efficiency of reciprocating pumps is very high, typically 85% to 90%.

**NPSHa** – An abbreviation that stands for Net Positive Suction Head Available. NPSHa is the total suction pressure, including allowance for acceleration head, available from the system at the pump suction connection, minus the vapor pressure of the liquid at actual pumping temperature. NPSHa for a reciprocating pump is normally expressed in units of feet of water.

**NPSHr** – An abbreviation that stands for “Net Positive Suction Head Required”. This is the minimum total inlet pressure required by the pump for proper operation. This value is a function of pump design and speed and is determined by the pump manufacturer through a specific NPSH test. NPSHr should exceed NPSHa by at least 5 feet.

**PISTON PUMP** – A type of power pump that uses a cylindrical seal (piston) mounted on a holder to drive fluid through the valves. The piston seal reciprocates within a stationary cylinder.

**PLUNGER PUMP** – A type of power pump that uses a cylindrical plunger to drive fluid through the valves. The plunger reciprocates through a stationary set of seals known as packing.

**POWER END** – The portion of the pump that converts supplied rotary motion into linear motion used by the Fluid End to move the pumpage.

**POWER FRAME** – The major portion of a power pump that encloses and supports all other components of the power (or drive) end. It is called a pump case in old literature.

**POWER PUMP** – A reciprocating pump that drives the pumping element(s) using a slider crank mechanism. Power pumps are piston, plunger, or diaphragm type. All require a driver with a rotating shaft, such as a motor or engine, as a power source.

**PUMP VALVE** – A check valve that allows flow of liquid in one direction. American Mfg Company pumps have a series of two valves, one suction (inlet) and one discharge, per pumping cylinder.

**STROKE LENGTH** – The length of one complete, unidirectional motion of the piston or plunger. Stroke length is usually expressed in inches.

**VOLUMETRIC EFFICIENCY** – Volumetric efficiency (VE) is the ratio of actual pump capacity output to theoretical displacement. The volumetric efficiency is affected by the fluid being pumped and the discharge pressure.

## 17.0 Reference Information

Use the following section to record key information about your specific pump model. Information such as part and serial numbers will be needed when ordering service parts. This data may be found stamped on the metal nameplate located on the pump power frame. This area may also be used to make notations about special parts, procedures, phone numbers, or other important information related to your pump.

Pump Model \_\_\_\_\_

Serial Number \_\_\_\_\_

Rated Pressure \_\_\_\_\_

Rated Capacity \_\_\_\_\_

Rated Speed \_\_\_\_\_

Notes:

# 18.0 Maintenance Log

Date	Service By	Service Performed	Remarks